



aalco[®]
Exhaust Tubing Range

aalco®

Exhaust Tubing Range

The Aalco stock of Stainless Steel Products for Automotive Exhaust Systems includes a wide range of **Tube** and **Perforated Tube** along with **Fittings**, **MIG Welding Wire Reels/Coils**, **TIG Welding Rods** and **Grade 434 Wire Wool**.

- ◆ The Tube in grades 409 (1.4512) and 304 (1.4301) covers all the commonly used sizes from 32mm O/D x 1.2mm Wall to 153mm O/D x 1.5mm Wall. Standard lengths are 6m.
- ◆ The Perforated Tube range in grades 409 (1.4512) and 304 (1.4301) covers all the commonly used sizes from 32mm to 76.2mm O/D. The Perf patten is 6011 with 3mm holes and 5.66m pitch (25% open area) and standard lengths are 5.8m.
- ◆ 90 Degree and 45 Degree Elbows are stocked in grade 304 (1.4301) with a Satin Polished Finish.
- ◆ 0.8mm MIG Wire Reels/Coils are stocked in grades 308 and 316.
- ◆ Grade 316L TIG Rods are stocked in 1.6mm and 2.4mm.
- ◆ Stainless Steel Wire Wool rolls are stocked in grade 434 (1.4113).

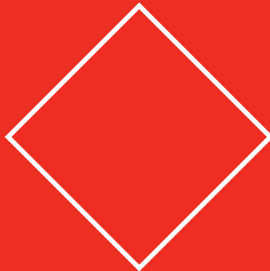
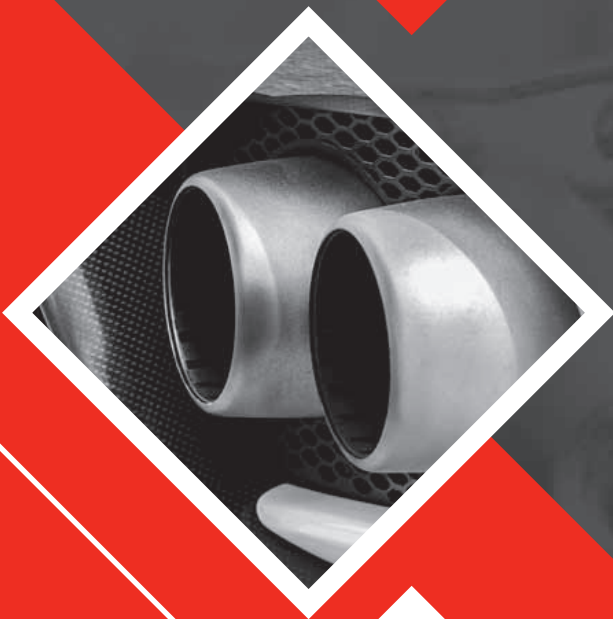

Exhaust Tubes



Stainless Steel Exhaust
Tube Grade 1.4512/409
Descaled (ETD)

Stainless Steel Perforated
Tube Grade 1.4512/409
Descaled (ETP)

32mm x 1.2mm
35mm x 1.2mm
35mm x 1.5mm
38mm x 1.2mm
38mm x 1.5mm
41.28mm x 1.2mm
41.28mm x 1.5mm
42mm x 1.5mm
44.45mm x 1.2mm
44.45mm x 1.5mm
45mm x 1.5mm
47.62mm x 1.2mm
47.62mm x 1.5mm

50mm x 1.5mm
50.8mm x 1.2mm
50.8mm x 1.5mm
54mm x 1.5mm
57mm x 1.2mm
57mm x 1.5mm
60mm x 1.5mm
63.5mm x 1.5mm
70mm x 1.5mm
101.6mm x 1.5mm
110mm x 1.5mm
127mm x 1.5mm

32mm x 1.2mm
35mm x 1.2mm
38mm x 1.2mm
41.28mm x 1.2mm
41.28mm x 1.5mm
44.45mm x 1.2mm
47.62mm x 1.2mm
50.8mm x 1.2mm
54mm x 1.2mm
57mm x 1.2mm
60.3mm x 1.2mm
63.5mm x 1.2mm
76.2mm x 1.2mm

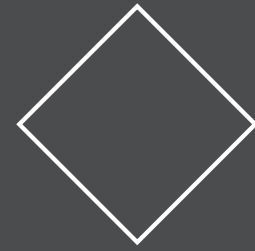

Stainless Steel Exhaust
Tube Grade 1.4301/304
Descaled (ETD)

Stainless Steel Perforated
Tube Grade 1.4301/304
Descaled (ETP)

32mm x 1.2mm
32mm x 1.5mm
35mm x 1.2mm
35mm x 1.5mm
38mm x 1.2mm
38mm x 1.5mm
41.28mm x 1.2mm
41.28mm x 1.5mm
42mm x 1.2mm
44.45mm x 1.2mm
44.45mm x 1.5mm
44.45mm x 2.0mm
47.62mm x 1.2mm
47.62mm x 1.5mm

48mm x 1.2mm
50mm x 1.2mm
50mm x 1.5mm
50.8mm x 1.2mm
50.8mm x 1.5mm
50.8mm x 2.0mm
54mm x 1.2mm
54mm x 1.5mm
57mm x 1.2mm
57mm x 1.5mm
57mm x 2.0mm
60.3mm x 1.2mm
60.3mm x 1.5mm
63.5mm x 1.2mm

63.5mm x 1.5mm
63.5mm x 2.0mm
70mm x 1.2mm
70mm x 1.5mm
76.1mm x 1.2mm
76.1mm x 1.5mm
76.2mm x 1.5mm
80mm x 1.5mm
88.9mm x 1.2mm
88.9mm x 1.5mm
101.6mm x 1.5mm
114.3mm x 1.5mm
127mm x 1.5mm
153mm x 1.5mm

32mm x 1.2mm
35mm x 1.2mm
38mm x 1.2mm
41.28mm x 1.2mm
44.45mm x 1.2mm
47.62mm x 1.2mm
50.8mm x 1.2mm
54mm x 1.2mm
57mm x 1.2mm
60.3mm x 1.2mm
63.5mm x 1.2mm
76.2mm x 1.2mm

Perforation pattern

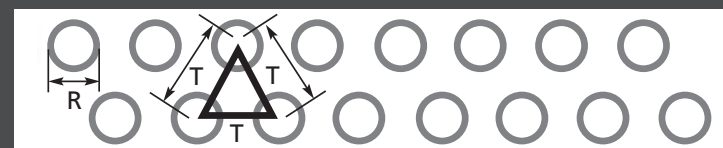
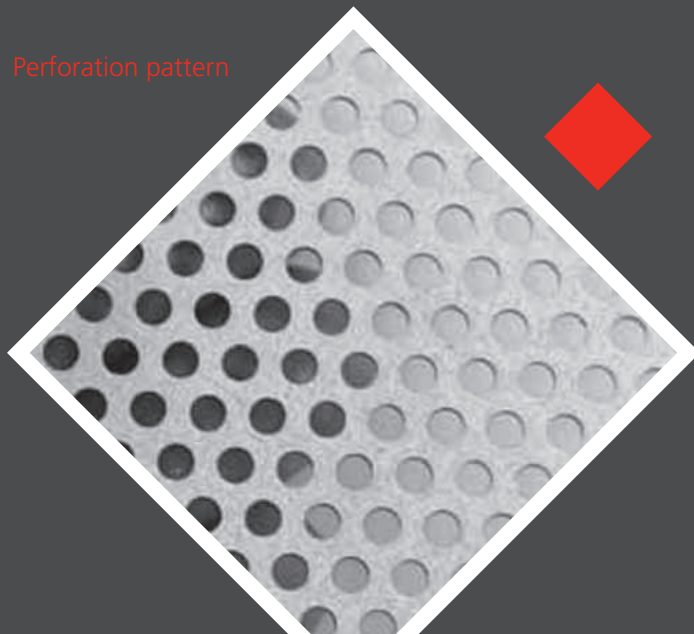

R = Diameter of Hole (3mm)

T = Pitch (5.66mm)

45° & 90° Elbows



BS Long 1.5D 45° Elbows
Grade 1.4301/304 Satin
Polished (EF)

38.1 x 1.65mm
50.8 x 1.65mm
63.5 x 1.65mm
76.1 x 1.65mm

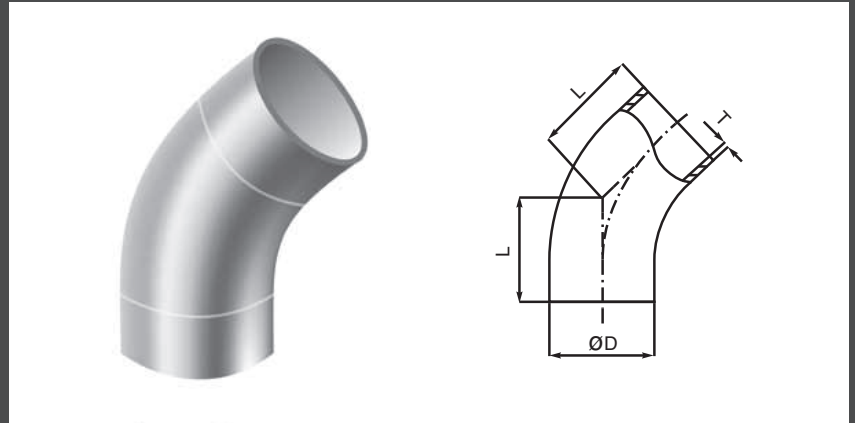

BS Long 1.5D 90° Elbows
Grade 1.4301/304 Satin
Polished (EF)

38.1 x 1.65mm
44.45 x 1.65mm
50.8 x 1.65mm
57 x 1.65mm
63.5 x 1.65mm
76.1 x 1.65mm

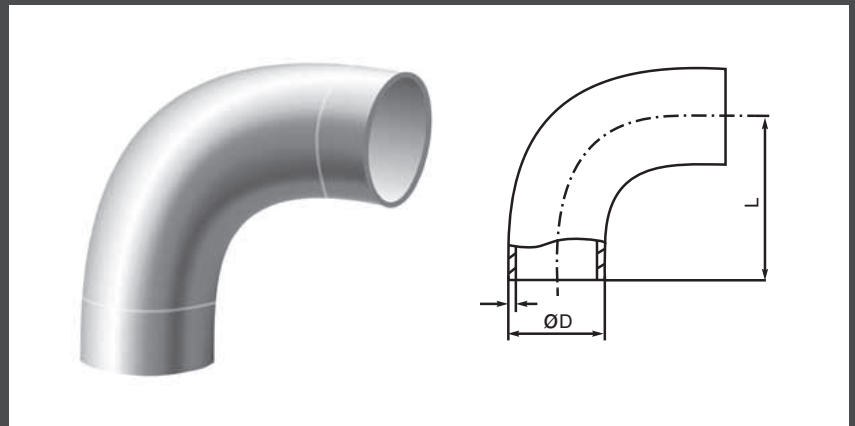

SMS Long 1D 90° Elbows
Grade 1.4301/304 Satin
Polished (EF)

38 x 1.25mm
51 x 1.25mm
63.5 x 1.5mm
88.9 x 1.25mm
101.6 x 1.25mm

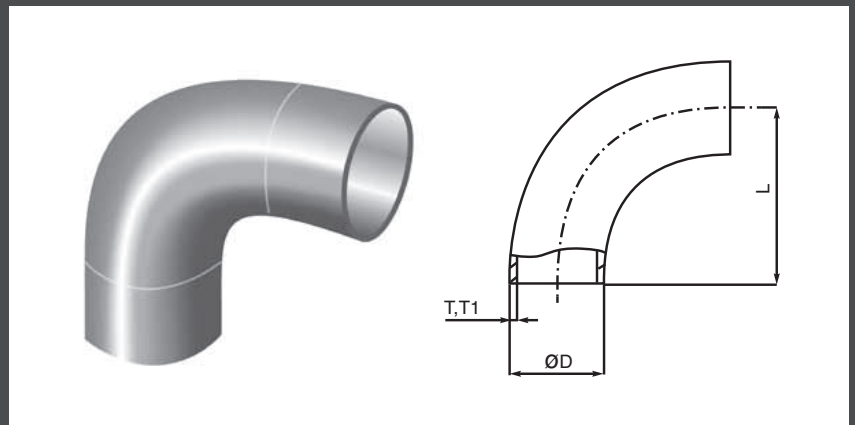

MIG & TIG Wire and Wire Wool

aalco®

MIG AND TIG Wire (EO)

0.8mm diameter MIG Wire Reels/Coils are stocked in grades 308 and 316.

The coils are approx 3000m long and weigh 15kg.

Grade 316L TIG Rods are stocked in diameters 1.6mm & 2.4mm. The rods are 1m long and come in 5kg boxes.



Stainless Steel Wire Wool (EO)

6.5kg reels of Stainless Steel Wire Wool are stocked in grade 434 (1.4113). The rolls are 100mm wide and have an O/D of 500mm to 600mm

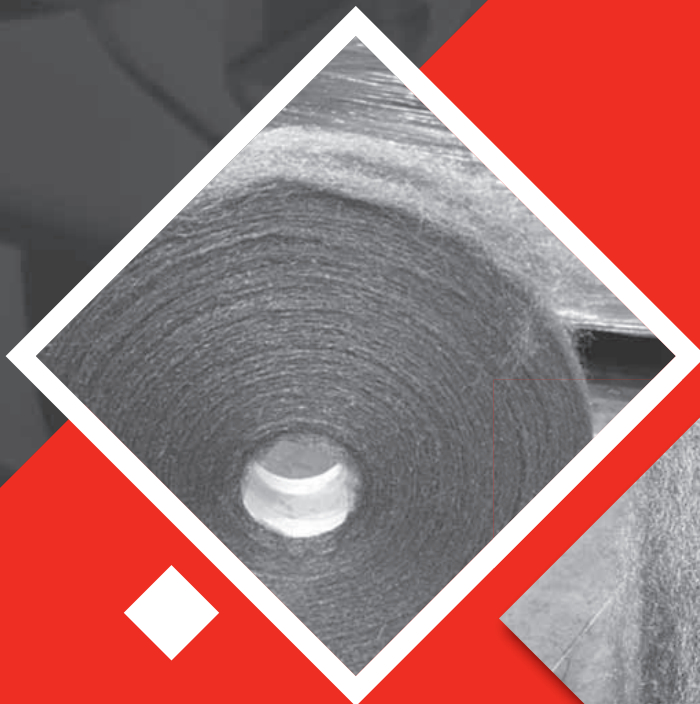



aalco[®]

www.aalco.co.uk

ABERDEEN

Tel 01224 854810
Fax 01224 871982
e-mail aberdeen@aalco.co.uk

AYLESBURY

Tel 01296 461700
Fax 01296 339923
e-mail aylesbury@aalco.co.uk

BELFAST

Tel 02890 838838
Fax 02890 837837
e-mail belfast@aalco.co.uk

BIRMINGHAM

Tel 0121 5853600
Fax 0121 5856864
e-mail birmingham@aalco.co.uk

CHEPSTOW

Tel 01291 638638
Fax 01291 638600
e-mail chepstow@aalco.co.uk

DYFED

Tel 01269 842044
Fax 01269 845276
e-mail dyfed@aalco.co.uk

ESSEX

Tel 01268 884200
Fax 01268 884220
e-mail essex@aalco.co.uk

GLASGOW

Tel 0141 6463200
Fax 0141 6463260
e-mail glasgow@aalco.co.uk

HULL

Tel 01482 626262
Fax 01482 626263
e-mail hull@aalco.co.uk

LEEDS

Tel 0113 2763300
Fax 0113 2760382
e-mail leeds@aalco.co.uk

LIVERPOOL

Tel 0151 2073551
Fax 0151 2072657
e-mail liverpool@aalco.co.uk

MANCHESTER

Tel 01204 863456
Fax 01204 863430
e-mail manchester@aalco.co.uk

NEWCASTLE

Tel 0191 4911133
Fax 0191 4911177
e-mail newcastle@aalco.co.uk

NORWICH

Tel 01603 787878
Fax 01603 789999
e-mail norwich@aalco.co.uk

NOTTINGHAM

Tel 0115 9882600
Fax 0115 9882636
e-mail nottingham@aalco.co.uk

SOUTHAMPTON

Tel 023 8087 5200
Fax 023 8087 5275
e-mail southampton@aalco.co.uk

STOKE

Tel 01782 375700
Fax 01782 375701
e-mail stoke@aalco.co.uk

SWANLEY

Tel 01322 610900
Fax 01322 610910
e-mail swanley@aalco.co.uk

